

**CARACTÉRISTIQUES**

- Machine robuste.
- Tapis en PVC.
- Commande manuelle :  
**SM-520S**: par boutons.  
**SM-520F**: par levier.
- Vitesse 50 cm/sec.
- Tables relevables.

**FEATURES**

- Robust machine.
- PVC conveyor belts.
- Manual operation:  
**SM-520S**: by push buttons.  
**SM-520F**: by handle.
- Speed 50 cm/sec.
- Tables can be raised after operation.

**EIGENSCHAPPEN**

- Robuste machine.
- PVC transportbanden.
- Handbediening:  
**SM-520S**: met drukknop.  
**SM-520F**: met hendel.
- Snelheid 50 cm/sec.
- Opklapbare tafels.



Tables relevables.  
Tables can be raised after operation.  
Opklapbare tafels.

Tapis en PVC.  
PVC conveyor belts.  
PVC transportbanden.



Équipé avec roulettes  
pourvues de frein, facile à déplacer.

Mounted on castors with locking  
system, easily movable.

Uitgerust met zwenkwielen  
met rem, makkelijk te verplaatsen.

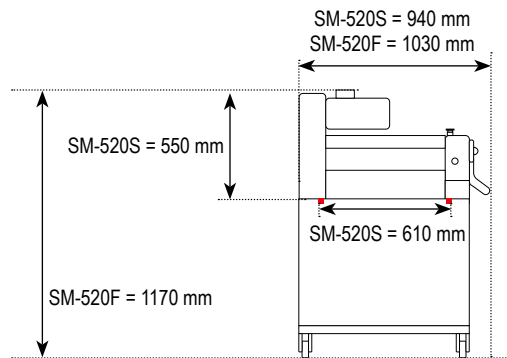
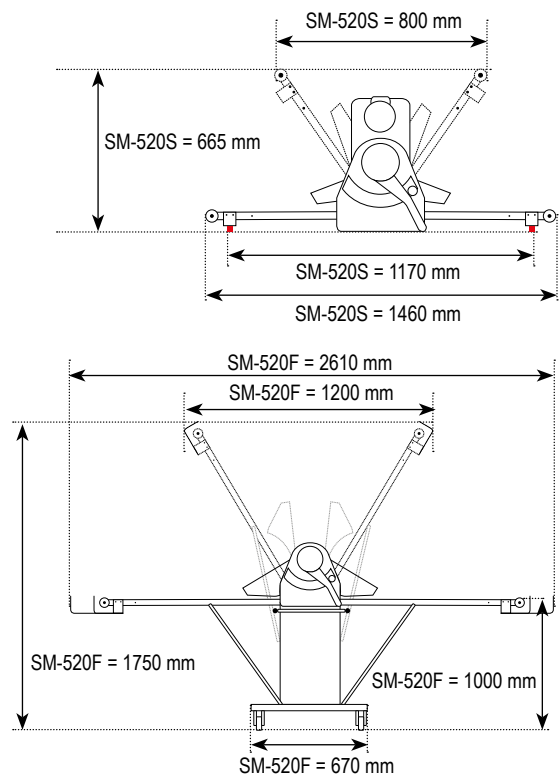
**VUE LATÉRALE | SIDE VIEW | ZIJAANZICHT**

**VUE DE FACE | FRONT VIEW | VOORAANZICHT**

**SM-520S**

**SM-520F**

MODEL	SM-520S	SM-520F
MODÈLE SUR SOCLE   MODEL WITH SUPPORT   SOKKELMODEL	✗	✓
PUISSANCE MOTEUR   MOTOR POWER   MOTORVERMOGEN	0,37 kW	0,55 kW
POIDS NET MACHINE   NET WEIGHT MACHINE   NETTOGEWICHT MACHINE	100 kg	168 kg
LARGEUR DU LAMINAGE   WORKING WIDTH   UITROLBREEDTE	520 mm	520 mm
LONGUEUR DU TAPIS   CONVEYOR BELT LENGTH   LENGTE TRANSPORTBAND	2 x 670 mm	2 x 980 mm
ÉCART ENTRE LES ROULEAUX   SPACE BETWEEN ROLLERS   RUIJMTTE TUSSEN DE ROLLEN	1 - 30 mm	1 - 30 mm
VOLTAGE   VOLTAGE   SPANNING	230/400V 3Ph 50Hz 230V 1Ph 50Hz	x 230/400V 50Hz